

專業設計與生產直壓式射出機與雙色射出機。

We specialize in design and manufacture hydraulic and two color injection moulding machine.

# CD-200 series CD-300 series

## Dual color injection moulding machine

### 雙色射出成型機

Dual color injection moulding machine

項目 Item	單位 Unit	CD-200			CD-300			CD-300WE			
		前方 F	後方 R		前方 F	後方 R		前方 F	後方 R		
<b>射出單元 Injection unit</b>											
螺桿直徑	Screw Dia.	mm	32 36 40	32 36 40	36 40 45	36 40 45	32 36 40	32 36 40	32 36 40	32 36 40	
射出容量	Inj. Volume	cm <sup>3</sup> /shot	101 127 157	101 127 157	148 182 231	148 182 231	116 148 182	116 148 182	116 148 182	116 148 182	
射出重量	Inj. Capacity	g/shot(ps)	96 120 150	96 120 150	132 162 206	132 162 206	110 132 162	110 132 162	110 132 162	110 132 162	
可塑化能力	Plasticizing Rate	kg/hr(ps)	28 38 52	28 38 52	43 59 80	43 59 80	32 43 59	32 43 59	32 43 59	32 43 59	
射出壓力	Inj. Press	kgf/cm <sup>2</sup>	2390 1890 1530	2390 1890 1530	2270 1840 1455	2270 1840 1455	2875 2270 1840	2875 2270 1840	2875 2270 1840	2875 2270 1840	
射出率	Inj. Rate	cm <sup>3</sup> /sec	127 160 198	127 160 198	154 191 241	154 191 241	122 154 191	122 154 191	122 154 191	122 154 191	
射出行程	Screw Stroke	mm	125			145			145		
螺桿轉速	Screw Speed	rpm	0-240			0-300			0-295		
射座行程	Nozzle Stroke	mm	280			380			380		
射嘴接觸力	Nozzle Force	mm tonf(kn)	3.5 (34)			3.5 (34)			4 (39)		
射嘴中心距	Nozzle Distance	mm	330			430			500		
<b>鎖模單元 Clamping unit</b>											
鎖模力	Clamp Force	tonf(kn)	200 (1960)			300 (2940)			307 (3008)		
鎖模行程	Clamp Stroke	mm	500			600			850		
最小容模厚度	Min. Thickness	mm	200			200			300		
最大開模距離	Daylight Open	mm	700			800			1150		
大柱間距(對角間距)	Tie Bar Distance	mm	530 x 530 (784)			660 x 660 (976)			935 x 645 (1183)		
模板尺寸(轉盤直徑)	Platen Size	mm	780 x 780 (720)			955 x 955 (906)			1255 x 960 (1118)		
頂出行程	Ejector Stroke	mm	142 (註：頂出轉盤外為 75 mm)			172 (註：頂出轉盤外為 85 mm)			172 (註：頂出轉盤外為 85 mm)		
頂出力	Ejector Force	tonf(kn)	4 (39) x 2 支 piece			4.9 (48) x 2 支 piece			5.6 (54) x 2 支 piece		
開模力	Open Mold Force	tonf(kn)	9 (88)			12 (117)			12 (117)		
<b>電氣及其他 Other</b>											
最高迴路壓力	Max. Syst. Press	kgf/cm <sup>2</sup>	175			175			175		
油泵馬達	Motor Power	kw(hp)/pole	30 (40)/6			45 (60)/6			45 (60)/6		
電熱容量	Heater Capacity	kw	7.4 + 7.4 = 14.8			8.3 + 8.3 = 16.6			8.3 + 8.3 = 16.6		
作動油量	Hyd. Oil Req.	l	580			700			1200		
機器尺寸 LxWxH	Machine Size	m	5.7 x 1.5 x 1.95			5.5 x 1.5 x 2			6.1 x 1.8 x 2		
底座尺寸	Floor Spaca	m	4.5 x 1.3			5.1 x 1.4			5.6 x 1.7		
機器重量	Machine Weight	ton	9			12			13		



群基精密工業股份有限公司  
CREATOR

CREATOR PRECISION CO., LTD.  
30, Lane 265, Jhongshan Rd. Sec. 1, Wurih  
Taichung, 41472 Taiwan.  
41472 台中市烏日區中山路一段265巷30號  
TEL: +886-4-23376000(Rep)  
FAX: +886-4-23379000  
E-mail: info@creatoredm.com  
http://www.creatoredm.com

ead LEAD

蘇州群倫精密機電工業有限公司  
蘇州市吳中區胥口鎮胥江工業園時進路499號  
電話: 86-512-66311366 傳真: 86-512-68242846  
東莞分公司  
電話: 86-769-85320266 傳真: 86-769-85327273



Daya 04-24521567-2012.11.2000

# CD-Series

## 特性 |

1. 兩組獨立之射膠單體，可同步或獨立做射出動作，雙色一次成型，可大幅縮短成型週期。
2. 直壓鎖模設計，模具變形量小，成型精度更高。
3. 射出兩組及夾模均採用電阻小，可準確控制開關模及射出形成，準度可達 0.1mm。
4. 螺桿與料管採用 ACM2 合金鋼材，經離子氮化處理，耐腐蝕且耐磨性高。
5. 每組料管具備 4 段 PID 溫度控制，可控制溫度在  $\pm 1^{\circ}\text{C}$ 。
6. 可採用透明管式水流分布器，以調整最佳溫度控制，提高產品品質。
7. 雙組頂出油路，應用更方便。
8. 轉盤負載超強 (CD-200，可達 1000KG)，保證合模不下降。轉盤精度高，速度快，轉速可達 2 秒 / 180 度
9. 採用日本 STAR 先進的人機界面控制器，10 吋彩色 LCD 超大型電腦螢幕，操作容易。

## Features |

1. Two independent injection unit can reduce the cycle time.
2. Hydraulic clamping unit, the mould deformation is very less and the injection moulding is more accuracy.
3. Linear transducer for the injection, clamping position control.
4. Screw and barrel made by ACM2 material process with nitride for high wear resist.
5. Four heating zone controller by PID the accuracy can reach to  $\pm 1^{\circ}\text{C}$ .
6. Two independent ejector designs for easy operation.
7. Advance turntable mechanism design for fast moving and precision positioning.
8. Heavy duty turntable (CD-200 may reach to 1000 kg) to ensure the mold do not falling operation. High precision and speed turntable, the speed can reach to 2 second / 180°
9. Advance japan made star controller with 10" color LCD screen for easy operation.

# 雙色射出成形機鎖模單元

## Clamping Unit of CD-Series Plastic Injection Molding Machine

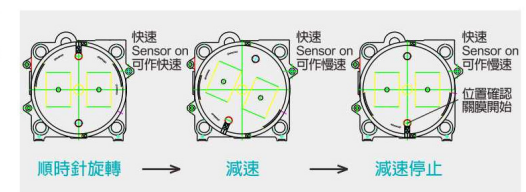
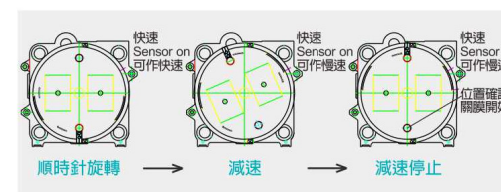
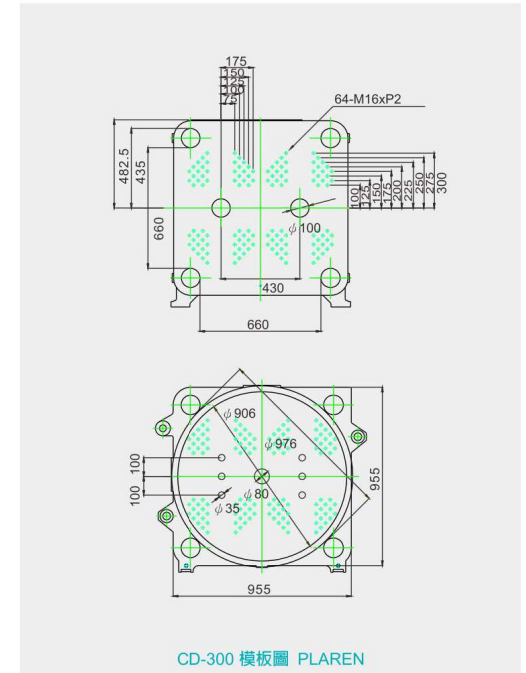
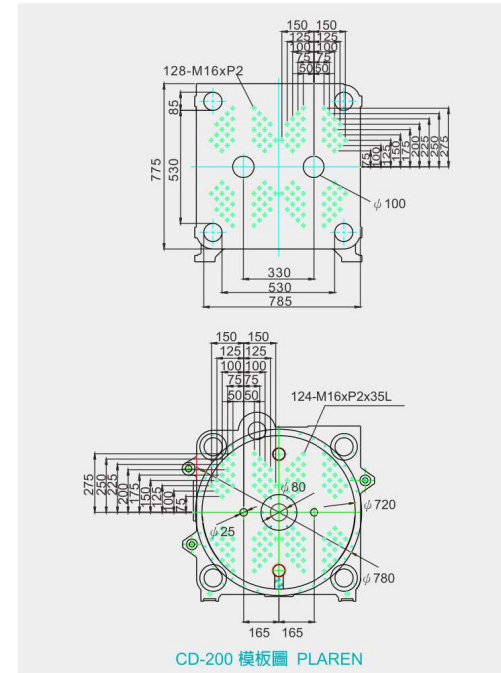

## 3C 產業的生產利器，讓您無往不利。



● 直壓式鎖模結構  
Hydraulic Clamping Structure

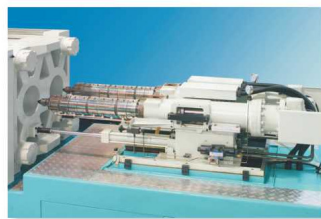

● 模組化射出單體  
Module Injection Unit



● 單缸射出. 優良塑化能力  
Single Injection Cylinder.  
Excellent plasticize capability.

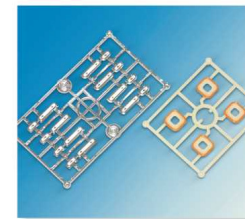

● 高穩定性射出, 精密成品  
Holding evenly with  
perfectly parallel platen.



● 高速薄片成形, 厚度均勻, 內應力低  
High plasticizing and good hold pressure.

